

ST Microelectronics Solar Reference Designs

Available from Avnet



Accelerating Your Success™

Semiconductor reference designs for solar

Improved performance and efficiency



3 kW converter for grid-connected PV systems

Overview

DC-DC converter based on phase-shift FB control of primary and secondary switches by MPPT algorithm

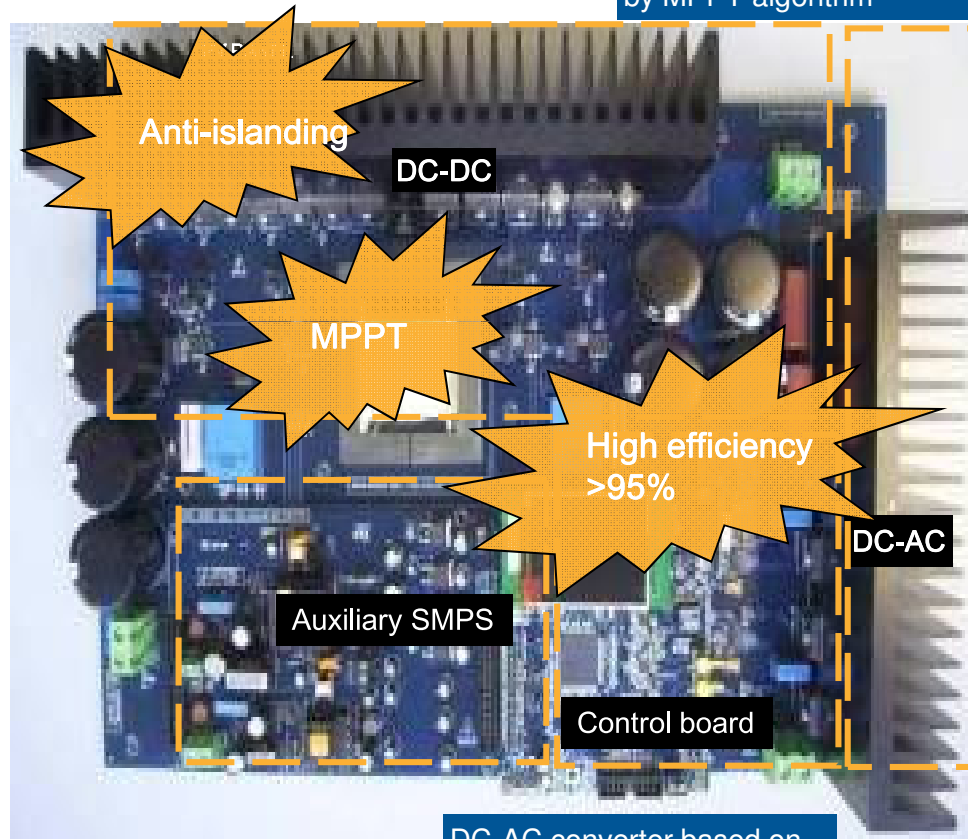

DC-AC converter based on current mode PWM control for grid connection by DC bus voltage control

Specification	Value
DC-DC input voltage	200 V – 400 V
DC-DC output voltage	450 V
DC-AC output voltage	230 Vac
Nominal output power	3 kW
DC/AC switching frequency	17 kHz
DC/DC switching frequency	35 kHz
Transformer turn ratio	1.22
Transformer magnetizing inductance	2.1 mH
Transformer leakage inductance	35 μ H
Max average input current @ 200 V	16.1 A
Primary switch peak current	36.3 A

Part Number: STEVAL-ISV002V1

3 kW converter for grid-connected PV systems

System architecture: main components

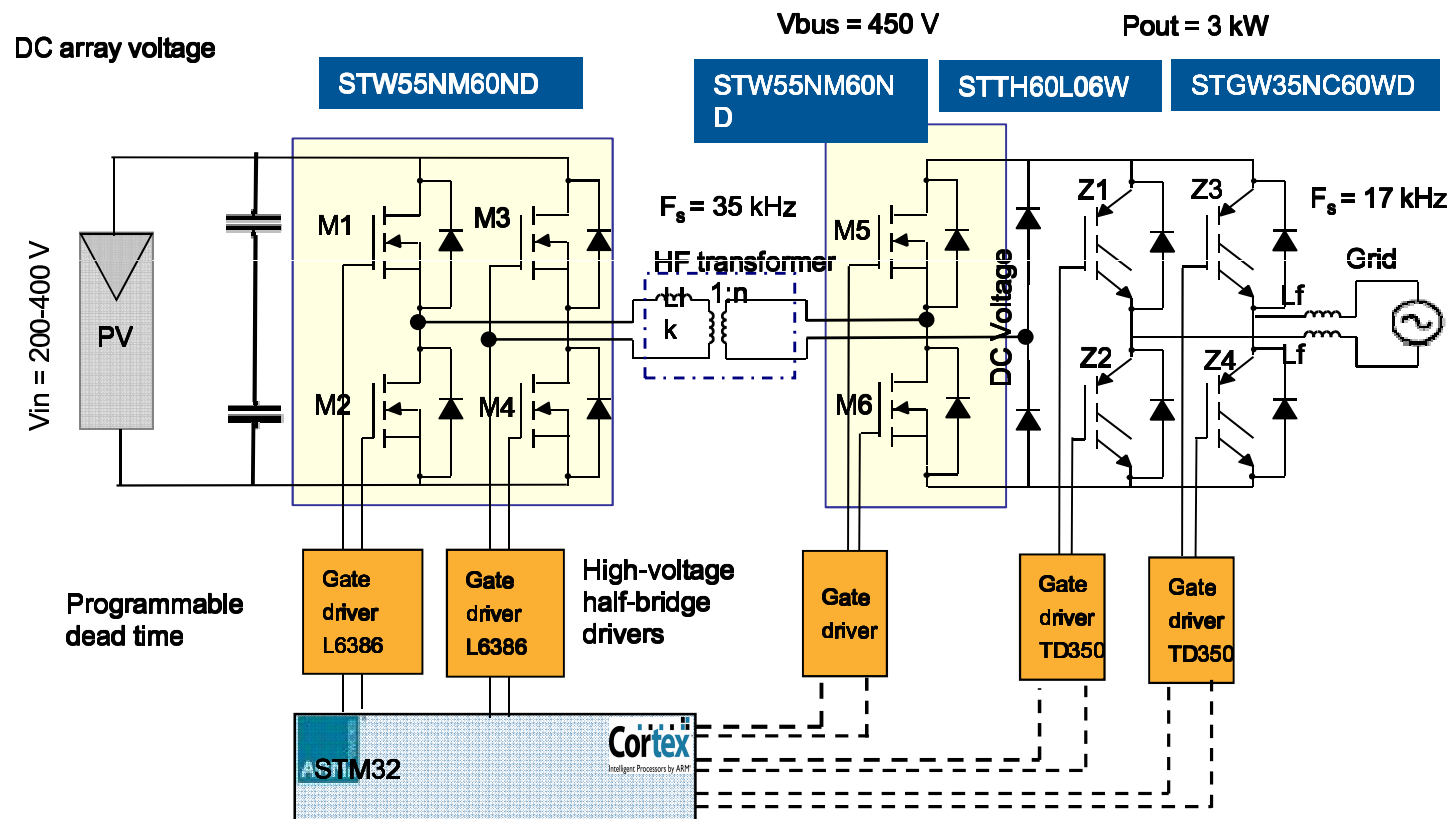

3 kW converter for grid-connected PV systems

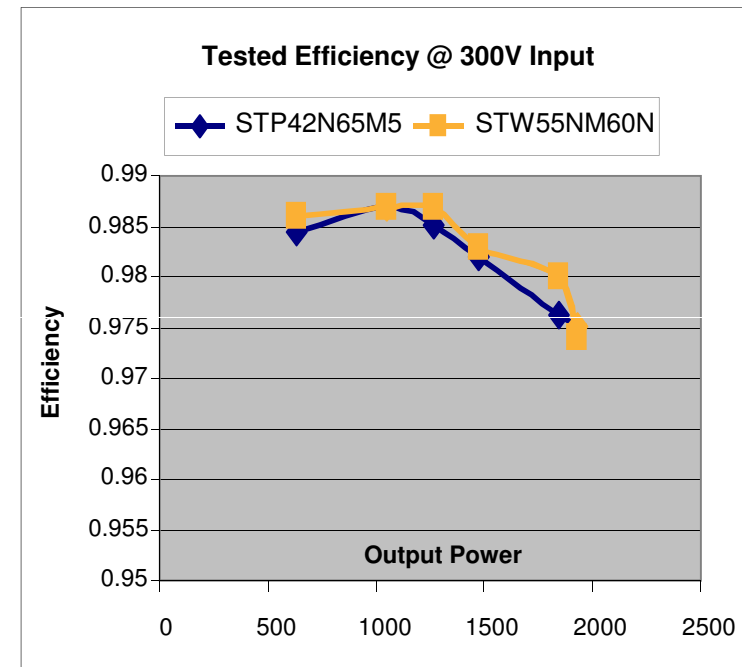
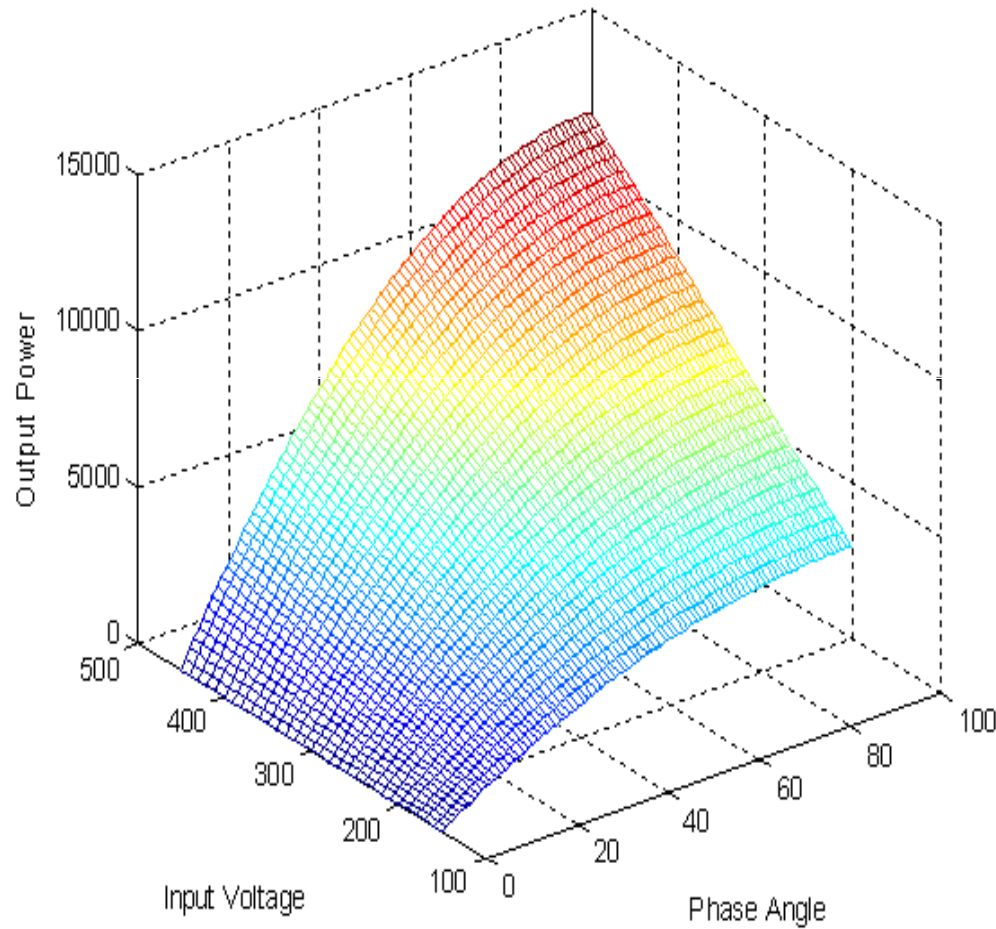

DC-DC converter power transfer

1 KW Inverter Specifications

- Nominal input voltage: 24 V
- Output voltage: 230 Vrms, 50 Hz
- Output power: 1 kW
- Efficiency: 92%
- Switching frequency: DC-DC: 100 kHz
DC-AC: 15 kHz

Key products:

- STP160N75F3
- TGW20NC60WD
- SG3525

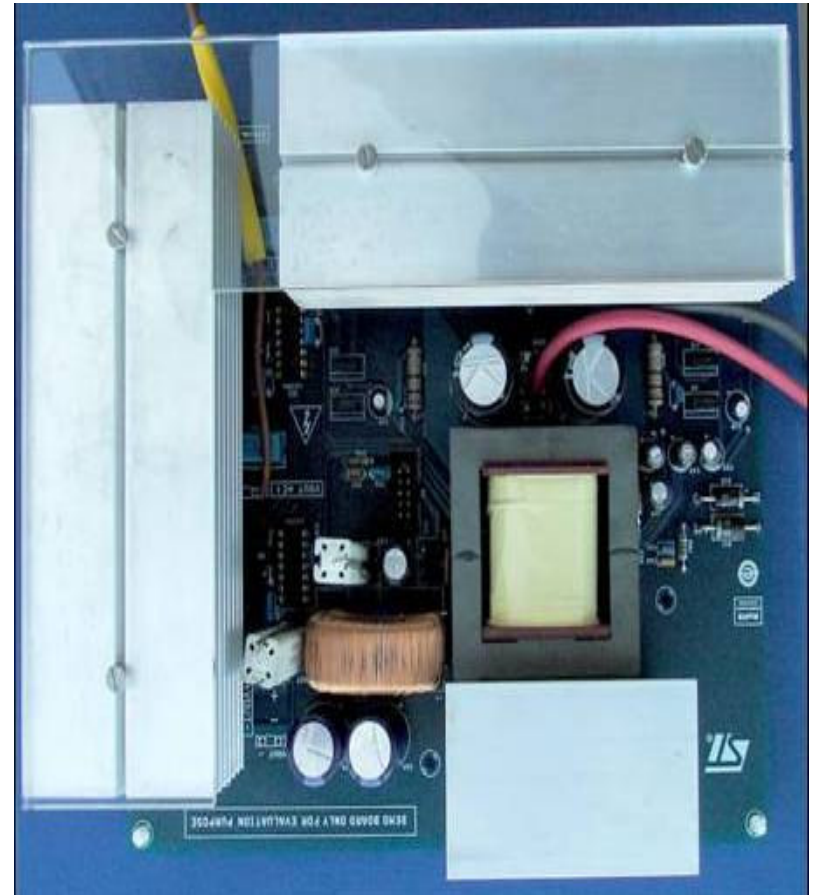

Part Number: STEVAL-ISV001V1

1 KW Inverter Block Diagram

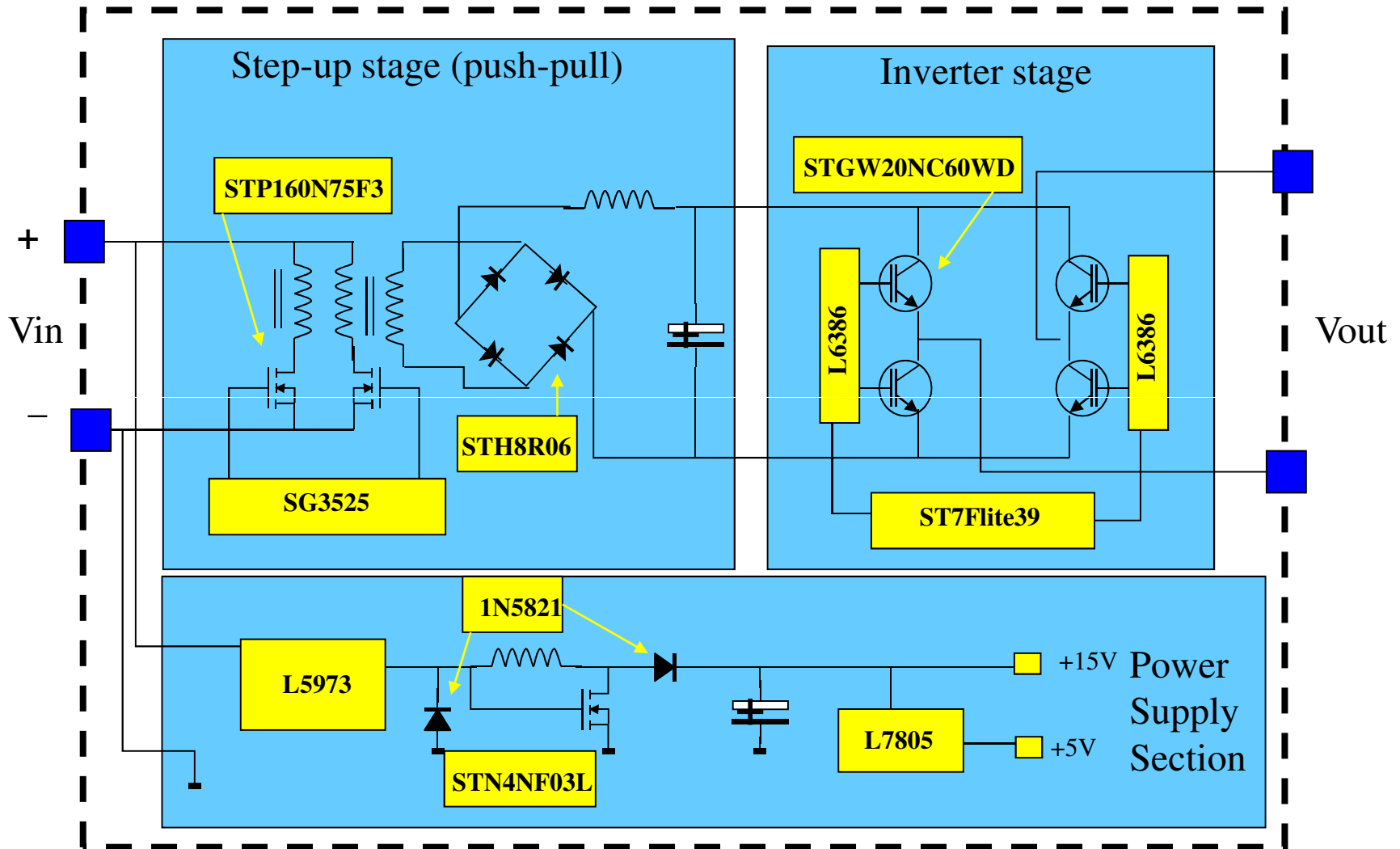

1 KW Inverter

