

# MedicalElectronics

*Review*

FEB 2011 // VOL 2 // ISSUE 1



Medical Electronics Solutions

## DESIGN FOR A HEALTHY PRODUCT LIFECYCLE WITH AVNET ELECTRONICS MARKETING

PAGE 2

### IN THIS ISSUE

- ANALOG DEVICES
- EMERSON NETWORK POWER
- FREESCALE SEMICONDUCTOR
- INTEL
- MAXIM
- NATIONAL SEMICONDUCTOR
- PANASONIC
- TEXAS INSTRUMENTS

ANALOG DEVICES  
PRECISION CONVERTERS AND AMPLIFIERS

PAGE 4

NATIONAL SEMICONDUCTOR  
EIGHT-CHANNEL TRANSMIT/RECEIVE CHIPSET

PAGE 9

PANASONIC  
BLUETOOTH® MODULES

PAGE 10



# DESIGN FOR A HEALTHY PRODUCT LIFECYCLE WITH AVNET ELECTRONICS MARKETING

By Nick Lukianov, Director, Vertical Segment Business Development, Avnet Electronics Marketing and Joanne Nania, Director, Vertical Segment Business Development, Avnet Electronics Marketing

There are many considerations that medical device Original Equipment Manufacturers (OEMs) must think about on their next-generation medical device designs. These include, but are not limited to ease-of-use, integration of complex functions, reliability, reduction in size, increase in performance, expansion of feature sets, communications capability and reduction in cost. With groundbreaking levels of integration, Avnet Electronics Marketing and our line card suppliers are able to address all of these key considerations.

Avnet continues to work closely with the medical device OEM community in the development of new patient therapy, diagnostic, monitoring and imaging technologies, as well as various additional patient care solutions. In concert with our supplier partners, Avnet provides technology and supply chain support that helps ease the compliance process, accelerate time-to-market and ensure a long product lifecycle. Our experience with a wide variety of application-specific devices has helped us gain insight into certain trends, ensuring that we offer the OEM community the broadest array of differentiating technology solutions.

## CHANGING PATIENT THERAPY MODELS

---

Patient therapy models, such as “Point of Care” are changing at a rapid rate. In order to receive any type of care, patients previously had to visit their respective physicians. Now, however, with mobile Point of Care units patients can be diagnosed and receive treatment from the comfort of their own homes or hospice care facilities. These mobile Point of Care units are equipped with diagnostics, monitors, communications systems and IP based services — all of which allow a physician to monitor and/or distribute medication as needed.

Key advances in technology have facilitated the Point of Care unit development, as well as many other developments in medical design. For example, where a discrete device silicon solution once negatively impacted size and reliability, ASSPs (Application Specific Integrated Circuits) have become cornerstone to simplifying a design, reducing size and cost, and increasing reliability, both from a device and manufacturing perspective. In addition, the continued increase in sophistication of MEMS devices has opened up the field of micro fluidics, wound care, patient mobility sensing and wellness care.

Semiconductor process and packaging technology are also driving advances in medical devices and patient care. The amount of processing power that can be integrated into a small 100 mm<sup>2</sup> footprint is approaching the performance of today’s desktops. In addition, these solutions provide all the necessary memory management and video processing, along with a variety of communications protocols. Sophisticated process and packaging technology such as System in Package (SiP), Through Silicon Vias (TSV), Stacked Die (Stacked Chip Scale Package), wafer level Chip Scale Package (CSP) are all examples of packaging that are being leveraged in medical devices and leading to considerable reduced size.

## SUPPLY CHAIN SERVICES

---

To ensure success with the definition, design, development, validation, compliance and long-term sustainability requirements of a medical device, designers and manufacturers must partner with a component and supply chain resource that understands the unique product and lifecycle requirements of the medical OEM. Avnet has invested heavily in a suite of product lifecycle management tools and has cultivated company-wide supply chain expertise that can be utilized by customers’ quality and purchasing teams in order to fulfill specific compliance requirements and meet critical materials management objectives.

For example, as the FDA continues to scrutinize and act as a regulatory influence on the medical device OEM supply chain, from component sourcing to product lifetime deployment monitoring, Avnet offers medical OEMs a comprehensive suite of supply chain services that address all facets of a production lifecycle. These services, which start with bill of material management and run through the BOM Optimizer solution, will better help medical OEMs meet stringent FDA regulations. With the BOM Optimizer tool, Avnet provides access to the latest information on millions of components from leading worldwide manufacturers. This BOM management tool helps companies increase their component selection efficiency, avoid part obsolescence and compliance issues, and improve advanced BOM analysis. Environmental data includes details on RoHS substance concentration, as well as other relevant information. The tool provides manufacturer documentation, from current and historical datasheets and product change notices, to timing diagrams and application notes. In addition, the tool allows for advanced BOM optimization such as BOM cleansing, and matching and grading. Users can proactively receive product end-of-



life or product-change notifications and compare BOMs to check for part duplication. This information and data capture directly contributes to the tracking requirements imposed by the FDA.

Beyond BOM management, Avnet also provides standard and customized solutions for inventory reserve and bonding, automated release triggers including point of use replenishment and in-depth supply chain assessment and process mapping. Supply chain support extends into obsolescence management, as well, with custom solutions that are designed to provide an early warning about components entering the end-of-life phase. This may also include other forms of product lifecycle data that are intended to help prevent production disruptions when the lifecycle of an end-product continues beyond the lifecycle of its parts. Responding to the growing dilemma of product obsolescence, Avnet has partnered with several industry-leading aftermarket component manufacturers to provide customers with alternatives to complete board redesigns. These services provide real-time options in the face of component obsolescence disruptions.

In addition, Avnet understands the importance of providing detailed information to fulfill the requirements of a Device Master Record, and we have extensive experience helping customers navigate validation/verification, clinical trial and compliance hurdles. We also know that traceability and sustainability are critical issues when it comes to managing an extended product lifecycle. As a result, we scrutinize product roadmaps from our supplier partners to ensure the devices we recommend today will also be available in the long-term, preventing potential production disruptions that can result from unexpected end-of-life notifications on devices critical to a design.

## ACCELERATING YOUR SUCCESS

Avnet markets, distributes and adds value to leading-edge products available from the world's leading electronic component and enterprise computing manufacturers as well as embedded subsystem providers, serving both established and emerging medical device manufacturers and ISO13485-compliant contract manufacturers. The products we sell are backed by a host of supply chain, design chain and physical value-add services.

DESIGN CHAIN SERVICES	SUPPLY CHAIN SERVICES	VALUE-ADD SERVICES
ASIC Design Solutions	Premiere BOM Optimizer	Commercial Interconnect
FPGA Design Solutions	Bonded Inventory Planning Program	Custom Cable Assembly
Board-level Solutions	Electronic Data Interchange	High-Reliability Interconnect
Field Application Engineers	InPlant Stores	Motor Modification
Technical Consultation	Obsolescence Services	Power Supply Modification
Technical Education	Point-of-Use Replenishment Program	Thermal Management
Design Tools	Supply Chain Assessment	Device Programming
LCD Display Solutions	SupplyFrame GoPart	Tape & Reel
Integration Services	Vendor Managed Inventory	Customized Packaging

Avnet also specializes in computer system configuration as well as logistic and integration solutions. Avnet Logistics is comprised of 48 specialized logistics operations around the globe and utilizes two million square feet for warehousing and value-add activities. Our logistics centers are ESD-compliant per the JESD625 JEDEC standard. Each facility is also registered to the ISO 9001:2000 standard, and large distribution centers in Europe and the Americas are registered to the ISO 14001:2004 environmental standard. Some facilities are also registered to ISO/TS 16949:2002 and ISO 13485:2003 where appropriate.

These specialized services and solution centers provide cost and time-to-market advantages that allow medical OEMs to concentrate on the aspects of their business that provide the most return. Our innovative and entrepreneurial spirit, and our passion for customer service assures customers and suppliers that they have chosen the right partner to accelerate their success. Learn more about our comprehensive medical solutions at [www.em.avnet.com/medical](http://www.em.avnet.com/medical).

## AD7798 ADC

- » Low power, complete analog front end that contains a low noise, 16-bit  $\Sigma$ - $\Delta$  ADC with three differential analog inputs
- » On-chip features include a low-side power switch, reference detect, programmable digital output pins, burnout currents and an internal clock oscillator
- » Operates with a power supply from 2.7 to 5.25 and consumes a current of 300  $\mu$ A typical
- » Available in a 16-lead TSSOP package
- » 24-bit version, the AD7794 is also available

## AD8235 INSTRUMENTATION AMPLIFIER

- » Smaller than the tip of a pencil
- » Draws only 40  $\mu$ A (max) of supply current, yet features 6 nA shutdown current and 1 pA input bias current
- » Suited for power efficient, portable, lightweight medical devices and consumer health products, including heart rate monitors and activity monitors where a small size and long battery life are critical
- » Available in a 1.6  $\times$  2.0 mm WLCSP package
- » AD8236  $\mu$ SOIC version available

## AD8619 QUAD MICROPOWER OP AMP

- » Cost-efficient option for HRM designs, particularly when combined with the AD8235 in-amp and AD7798 ADC
- » Fully specified to operate from 1.8 to 5.0V single supply
- » Combines 22 nV/ $\sqrt{\text{Hz}}$  noise, 1 pA max input bias current, draws 38  $\mu$ A of supply current
- » Available in 14-lead TSSOP and 14-lead SOIC packages

# LOW-POWER PRECISION CONVERTERS AND AMPLIFIERS

## Offering Accuracy and Reliability at a Low Cost for Heart Rate Monitors

A heart rate monitor may be part of a complete health monitoring platform, including activity sensing, body fat analysis and temperature monitoring, or a stand-alone consumer grade device worn on the body or integrated into a piece of exercise equipment. All electronics required for signal processing and display must fit typically within one square inch or less, and the design must be highly cost efficient.

Analog Devices (ADI) offers low power precision converter and amplifier technologies for cost-sensitive heart rate monitoring devices used for health and wellness programs. ADI amplifiers and converters integrate tightly with additional technologies and functionality including USB port isolation, MEMS accelerometers, RF transceivers, touch control interface sensors and temp sensors, enabling flexible front-end electronic design that will support various HRM applications.

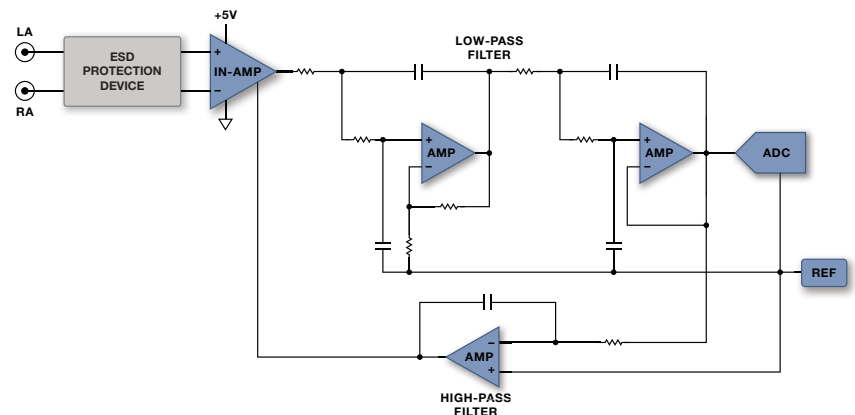

## Webcast: ECG and Heart Rate Monitoring Design Techniques

Analog Devices introduces a new technical webcast that takes an in-depth look at the major design challenges that are commonly encountered with ECG and heart rate monitor medical devices. This presentation provides a system overview and examines proven design techniques for controlling noise sources and EMI radiation, and analysis of various heart-monitoring and respiration monitoring functions.

Watch the the ECG and Heart Rate Monitoring Design Techniques Webcast at [www.analog.com/webcast/HRM](http://www.analog.com/webcast/HRM).

# CONNECTED HOSPITAL COMPUTING PLATFORM

## Improve Security and Software Management of Connected Hospital Digital Devices

Emerson Network Power's Embedded Computing business has revealed a proof-of-concept medical device computing platform that demonstrates how hospital IT professionals can secure and administer embedded medical devices centrally in the same way as PCs and servers.

The new proof-of-concept has been implemented as both an automated dispensing cabinet called MedDispense and a wireless mobile workstation, both of which are being demonstrated at industry events around the world. The technology behind this proof-of-concept can easily be replicated in other Connected Hospital applications such as a medical delivery cart or a mobile diagnostic system.

As healthcare providers digitize their medical records and integrate clinical systems, diagnostic data opportunities are emerging to simultaneously reduce cost, redundancy, administrative burden and medical errors, all while increasing the quality of care. The drive towards the "Connected Hospital" concept spans patient administration, health monitoring and care, imaging and diagnostics, and records management. However, network vulnerabilities expose a hospital to the risk of breaching patient confidentiality, of impairing patient care due to non-availability of data, and of attack by cybercriminals.

Hospital IT professionals have proven procedures for centrally administering the protection and security of network-attached enterprise computing equipment such as PCs, servers and laptops. But many embedded digital devices used in hospitals today cannot be controlled or secured in the same way. The Emerson Network Power proof-of-concept demonstrates a unified approach for bringing advanced remote management features and enhanced security to healthcare computing platforms.

At its heart is the MATXM-CORE-411-B from Emerson Network Power, a MicroATX format motherboard based on the Intel Core i7 processor. The system is managed by Altiris™ Client Management Suite from Symantec, a systems management solution that helps provision, manage and support client based systems. The proof-of-concept also demonstrates how the Symantec technology provides a familiar user interface for the Intel® Active Management Technology (Intel® AMT) feature that the Intel Core i7 processor provides. This enables the IT administrator to remotely connect to, troubleshoot and restart a device on the network even if its operating system has crashed, its hard drive has failed, it is in Sleep mode or software agents have malfunctioned. This feature only operates in client devices that contain an Intel processor with Intel AMT features enabled.

Learn more at [www.emersonnetworkpower.com/embeddedcomputing](http://www.emersonnetworkpower.com/embeddedcomputing).

### PROOF-OF-CONCEPT KEY FEATURES

- » MATXM-CORE-411-B, a MicroATX format motherboard based on the Intel Core i7 processor
- » System is managed by Altiris™ Client Management Suite from Symantec, a systems management solution that helps provision, manage and support client based systems
- » Demonstrates how the Symantec technology provides a familiar user interface for the Intel® Active Management Technology (Intel® AMT) feature that the Intel Core i7 processor provides
- » Enables the IT administrator to remotely connect to, troubleshoot and restart a device on the network even if its operating system has crashed, its hard drive has failed, it is in Sleep mode or software agents have malfunctioned



Emerson's MicroATX format motherboard based on the Intel Core i7 processor is at the heart of a new proof-of-concept computing platform for the Connected Hospital and has been implemented as both an automated medication dispensing system and a wireless mobile workstation.

## KIOSK FEATURES

- » Touch sensing interface allows users to toggle to different modes of operation
- » Touch sensing surface is easy to disinfect between uses — this is important for keeping pathogens such as bacteria and viruses away from the patient
- » Magnetic card reader is used to identify patients and to keep records of the patients' abbreviated e-chart with critical data, such as ID fields, family history, personal medical history and non-pathological personal history for blood type, alcoholism, tobacco and drug use or even allergies
- » Remote database is updated after testing and if a major or critical parameter is detected, an electronic report is sent to physician or caregiver
- » Telemonitoring solutions integrate a broad range of medical devices in order to achieve the physician's desired functionality while improving early diagnosis performance
- » State-of-the-art technology such as low power, analog integrated MCUs like Freescale's 8-bit MC9S08MM and 32-bit MCF51MM allow designers to achieve portability touch sensing with libraries that are downloadable for free —creating innovative solutions focused on preventative medicine

# REMOTE PATIENT MONITORING

## Providing Home Patients with Effective Medical Screenings

Freescale Semiconductor has created a medical kiosk as a reference design that allows easy and affordable telemonitoring to control, diagnose and help physicians to assess patients, and bring more hospital-type devices to patients' homes. The main core of the kiosk can be separated to form a home-use device that is portable and USB powered.

With the ability to continually monitor and control vital signs, physicians have advance warning of acute complications such as arrhythmias, hypoglycemia and edema. The medical kiosk or portable device keeps track of these parameters and uses mobile communications and databases to record all data and to alert physicians of possible emergencies, leveraging a wide range of devices such as glucometers, blood pressure monitors, EKG, heart rate monitors, weighing scales, pulse oximeters, spirometers (flow and lung volume) and thermometers. Integrating these devices with the adequate medical grade connectivity with a Continua Compliant personal healthcare device class (PHDC) USB and IT system helps to reduce and prevent major medical complications.

Freescale Medical Home Page  
[www.freescale.com/medical](http://www.freescale.com/medical)

Freescale and Monebo EKG On-a-Chip  
[www.monebo.com/partners.html](http://www.monebo.com/partners.html)

Freescale Tower Evaluation System  
[www.freescale.com/tower](http://www.freescale.com/tower)



PART NUMBER	APPLICATIONS
TWR-MCF51MM	Diagnostics EKG, Glucometer
TWR-MCF51MM-KIT	Diagnostics EKG, Glucometer
TWR-S08MM128	Portable EKG, Pulseoximeter
TWR-S08MM128-KIT	Portable EKG, Pulseoximeter
TWR-MPC5125	High end ECG, Ultrasound
TWR-MPC5125-KIT	High end ECG, Ultrasound
TWR-S08LH64	Segment LCD glucometer, Pulseoximeter
TWR-S08LH64-KIT	Segment LCD glucometer, Pulseoximeter
TWR-MCF5225X	Basic Telemonitoring Solutions
TWR-MCF5225X-KIT	Basic Telemonitoring Solutions
TWR-LCD	EKG, Glucometer
TWR-SENSOR-PAK	Blood Pressure Monitors, Touch Sensing, HMI
MED-EKG	EKG module for MC9S08 and MCF51 MM Tower

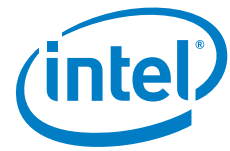

# WIRELESS PAN IMPLEMENTATION

## Fully Virtualized Environment

Due to their ease of use and flexibility, personal area networks (PAN) of wireless sensors are gaining wide deployment in healthcare settings including pre-hospital, in-hospital, ambulatory, home monitoring and long-term care. This proof-of-concept platform provides an example of Intel® Virtualization Technology (Intel® VT) in an application for the wireless remote acquisition of health information.

This demonstration combines the LynuxWorks LynxSecure Hypervisor\* simultaneously running Red Hat\* and Windows XP\* on a commercially available Portwell\* platform. Data is acquired from a network of SHIMMER\* wireless sensors, each with a Bluetooth radio and EMG sensor pads, capable of sensing a 70 mv differential between pads.

Intel VT, supported by embedded Intel® Core™ processors, allows multiple guest operating systems to target the most efficient application. In this case, the Red Hat software handles the near real time acquisition from the wireless sensors while XP handles rendering graphics and other OTS applications like Matlab\* or Excel\*.

The platform can be used to demonstrate the performance of the system with and without virtualization, and the relationship between payload and data loss, as the speed of data acquisition is modulated.

For more information, visit: <http://edc.intel.com/Applications/Medical/Remote-Acquisition-POC/>.

\*Other names and brands may be claimed as the property of others

### Wireless PAN Implementation in a Fully Virtualized Environment with Software Stack

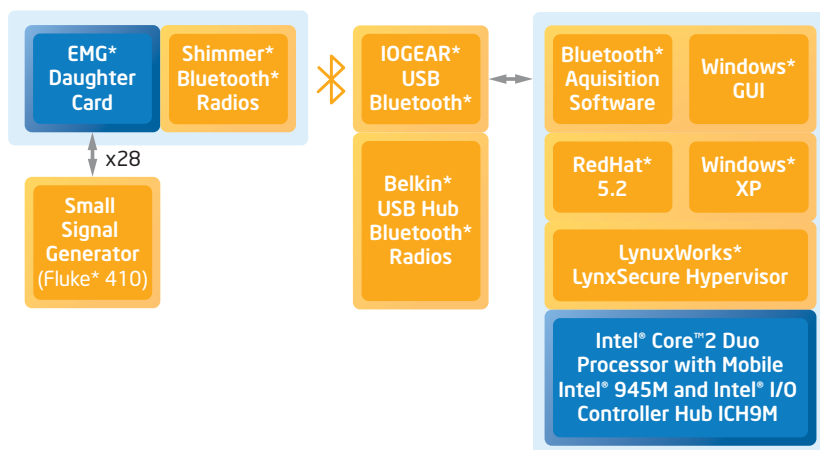

### DESIGN HIGHLIGHTS

- » Intel® VT allows RTOS to run simultaneously with Windows
- » System capable of running both VT-d and VT-x
- » Sensor with Bluetooth radio and EMG sensor pads capable of sensing to 70 mv differential between pads
- » Driver for the USB port capable of handling Bluetooth in the RTOS
- » System can handle up to 20 radios

### Remote Acquisition of Health Information Proof of Concept

<b>Processor</b>	Intel® Core™2 Duo Processor
<b>Chipset</b>	Intel® ICH9M
<b>Memory</b>	4 GB 800 DDR2 dual-channel
<b>Graphics connectivity</b>	x16 PCI Express* Graphics SDVO (dual-channel) 3 DisplayPort ports 2 HDMI ports
<b>Display</b>	LVDS CRT TV-out
<b>Storage</b>	4 Serial ATA Ports 120GB HDD
<b>IO</b>	12 USB 2.0
<b>Wireless PAN</b>	Bluetooth Radio

**MAXIM'S PRODUCTS ARE IDEAL FOR ALL MEDICAL APPLICATIONS AND THEIR UNIQUE NEEDS:**

- » Blood glucose meters
- » Blood pressure monitors
- » Computed Tomography (CT)
- » CPAP
- » Dialysis
- » Digital stethoscopes
- » Digital thermometers
- » Electrocardiograph (ECG)
- » Hearing aids
- » Heart-rate/fitness monitors
- » Infusion pumps
- » Insulin pumps
- » Magnetic Resonance Imaging (MRI)
- » Medical instruments
- » Positron Emission Tomography (PET)
- » Pulse oximeters
- » Sensor authentication and NV memory for data storage
- » Spirometers
- » Trim, calibrate and adjust
- » Ultrasound
- » Ventilators

# INSULIN PUMPS AND PORTABLE MEDICAL DESIGNS

Providing products that last through the product lifecycle and beyond.

Insulin pumps provide a precisely controlled rate of insulin delivery to diabetic patients who would normally need multiple daily injections to regulate blood glucose levels. Insulin pumps improve patient quality of life and reduce the incidence of long-term complications by providing tighter control of blood glucose levels. The firmware allows numerous modifications to the bolus dose and basal rate to enable patients to manage insulin levels in response to, and in anticipation of, events such as eating, sleeping and exercise.

The insulin is contained in a user-replaceable cartridge held inside the pump. This reservoir is effectively a specialized syringe with a piston that is slowly pressed by the pump. The cartridge output is connected to flexible tubing going to the patient's subcutaneous injection site, usually on the abdomen.

A related product for managing diabetes is a continuous blood glucose monitor. This device provides real-time glucose-level monitoring through a subcutaneous sensor. The sensor can be left in place for several days at a time, which reduces the need for the patient to test multiple individual blood samples. Future developments are expected to close the loop between these two systems by continuously monitoring the glucose level and, in response, automatically adjusting insulin dosage levels.

## FDA-regulated Medical Equipment

Insulin pumps are portable medical equipment whose design and manufacture is regulated by the Food and Drug Administration (FDA). This means that their design and construction must follow precisely documented processes, and their performance must meet stringent documentation, development testing, production testing and field maintenance requirements. The equipment also must contain comprehensive self-test and fault-indication capabilities, which require additional circuitry and the use of components that include self-test features.

Given the time and expense required to achieve FDA approval, manufacturers must select a supplier with a customer-oriented discontinuance policy to ensure that system components will be available for many years.

Medical customers rely on Maxim products because over the years Maxim has carefully avoided discontinuing parts. Maxim realizes how devastating product discontinuance can be to a customer, so they work diligently to transfer some products to newer production lines, create wafer buffers, allow last-time purchases or develop upgrade devices. Very few Maxim parts have ever been discontinued while demand still existed. Maxim's Discontinuance Policy is one of the most flexible among its peer supplier companies.

**INSULIN KIT BUNDLES:** Together with Avnet Electronics Marketing, Maxim is offering qualified registrants an Insulin Kit Bundle. Customers may register to qualify for one bundle each. Offer ends December 31, 2011, or while supplies last. Learn more at [www.em.avnet.com/mer/mxminsulinkit](http://www.em.avnet.com/mer/mxminsulinkit).



# EIGHT-CHANNEL CHIPSET

## Ideal for Portable Ultrasound Systems

Specifically designed for ultrasound systems used in hospitals, clinics, ambulances and remote point-of-care facilities, National's chipset allows designers to deliver high diagnostic image quality with low-power consumption. The PowerWise® chipset's innovative circuit architecture enables the design of both hand-carried and handheld units that deliver longer battery life and imaging performance comparable to larger console systems.

National provides a complete eight-channel transmit/receive (T/R) chipset, including receive analog front end (AFE), transmit/receive switch, transmit pulser and configurable transmit beamformer. This high-level of integration allows system designers to build lightweight 128-channel portable ultrasound systems with enhanced image quality and diagnostics in a small footprint. The chipset includes four ICs that work together to deliver unmatched performance and power efficiency.

Learn more at [www.national.com/ultrasound](http://www.national.com/ultrasound).

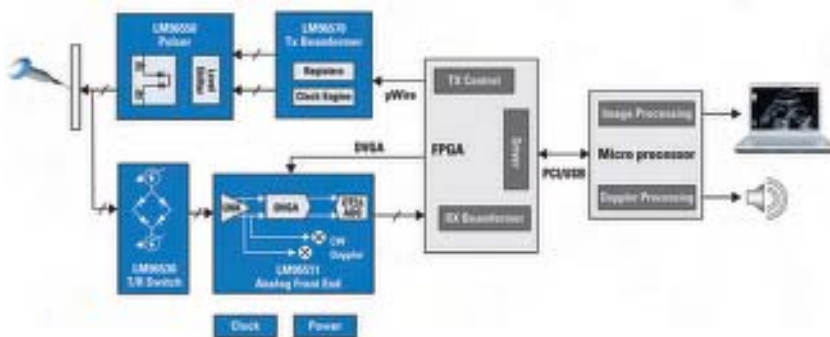

### LM96511 RECEIVE AFE

- » Integrates eight channels of LNA, DVGA, 12-bit, 40-50 MHz ADC with LVDS data outputs and eight demodulators for CW Doppler beamforming
- » Provides the lowest B-mode power consumption at 110 mW per channel
- » Delivers 161 dB/Hz of dynamic range, enabling measurement of low velocity blood flow in organs such as the liver through the integrated CW Doppler
- » Enhances image quality with channel-to-channel gain matching of +/- 0.06 dB (typical) that is four times better than the closest comparable AFE
- » Delivered in a 187 mm<sup>2</sup> package that is 27% smaller than any other comparable AFE

### LM96530 T/R SWITCH

- » Contains eight transmit/receive switches with integrated clamping diodes and offers an individual channel shut-off capability
- » Provides 55% better input referred noise (0.5 nV/√Hz) and 53% lower on-resistance (16 Ohms) compared to other devices, increasing receiver sensitivity and image resolution
- » Reduces board space by 4x compared to discrete solutions, and its daisy-chained SPI control reduces the number of FPGA I/O pins required for programming

### LM96550 TRANSMIT PULSER

- » Contains eight pulsers with damper circuit that generates +/- 50 V bipolar pulses with peak currents up to 2 A and pulse rates up to 20 MHz
- » Features over-temperature protection by continuously monitoring on-chip temperature and providing power-down logic output

### LM96570 TRANSMIT BEAMFORMER

- » Provides an order of magnitude jitter performance improvement (25 ps pk-pk) over beamforming traditionally done in FPGAs
- » Enables much higher resolution imaging in B-mode and low blood velocity measurements in CW Doppler mode
- » Simplifies board layout since system designers can place it directly next to the pulser, thereby avoiding the typical routing challenges of connecting an FPGA's IO pins to the pulser

## BLUETOOTH® MODULES

### Exceed Design Expectations

#### ADDITIONAL NEW BLUETOOTH RF MODULES

- » PAN1325 Series – HCI Bluetooth module with antenna
- » PAN1321 Series – Bluetooth HCI module with integrated SPP profile and antenna
- » PAN1555 Series – Bluetooth CSR, BC06 transceiver with embedded STM32 controller module with optional SPP or HTP profiles

#### BENEFITS

- » Reduced design cycle
- » Extended product life cycle
- » New revolutionary software alternatives
- » Wireless solutions for less

Panasonic Electronic Components provides powerful, highly flexible, cost-effective RF modules for a wide variety of wireless Personal Area Network (PAN) applications. New extended range products and small footprints combined with network firmware flexibility make Panasonic an industry leader in the development of cutting-edge RF module technology. Panasonic RF module solutions provide:

**Reduced Design Cycle.** Get wireless products to market faster by greatly reducing the design-to-production path. RF hardware design, development, debugging and test, board layout, quality testing and certifications are all removed by choosing a Panasonic RF module.

**Extended Product Life Cycle.** By providing a constant footprint and pin out over several generations of ICs that guard against the need to re-spin or redesign a wireless product, RF modules extend the product life cycle of any wireless product.

**New Revolutionary Software Alternatives.** Panasonic has partnered with several software developers for all of the major network protocols, including Bluetooth®, helping to reduce the time or software resources required to learn network stacks and develop applications, which can be both daunting and expensive.

**Wireless Solutions for Less.** Designing in an RF module rather than a discrete wireless solution can reduce expensive development, test, certification and production resource requirements.

#### New Bluetooth RF Modules

Bluetooth, which is based on IEEE 802.15.1, was developed for the purpose of sending larger amounts of data quickly from computers to PDAs to cell phones or other portable handheld devices. Panasonic offers a new Bluetooth RF module product line that makes connectivity between mobile devices such as cellular phones and small button cell battery powered devices like fitness sensors, watches, healthcare, entertainment and mobile accessories easily implemented, creating a seamless data chain from sensors to the Web.

The new PAN1315 Host Controlled Interface (HCI) Bluetooth RF module brings TI's seventh generation Bluetooth core integrated circuit, the CC2560, to an easy-to-use module format. Panasonic's tiny footprint technology has produced a module of only 58.5 mm<sup>2</sup>. The module is designed to accommodate PCBs pad pitch of 1.3 mm and as little as two layers for easy implementation and manufacturing. PAN1315 modules are designed to be 100% pin compatible with the next generation of Bluetooth Low Energy devices, allowing designers to seamlessly transition between Bluetooth Classic and Low Energy modules.

Learn more at [www.panasonic.com/rfmodules](http://www.panasonic.com/rfmodules).

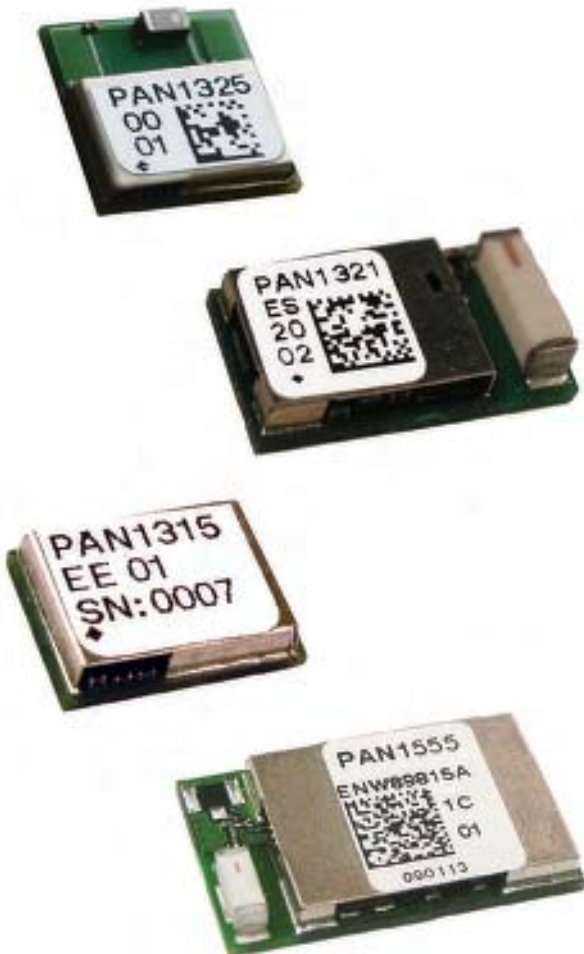

# ANALOG & EMBEDDED PROCESSING PRODUCTS

## Innovate Faster in Medical

With its full range of analog and embedded processing products, from building blocks to complete semiconductor solutions, TI is helping make innovative medical electronics more flexible, affordable and accessible, while maintaining the high standards for quality and reliability that the medical market demands.

### Innovative Semiconductor Solutions

- » Addressing growing needs for portability, connectivity, power efficiency, performance and precision
- » State-of-the-art process technology

### Complete Portfolio

- » Amplifiers, data converters, interfaces, power management, logic, DSPs, ultra-low power MCUs, ARM-based MPUs, wired and wireless connectivity, audio and video ICs, and many more
- » Catalog, application-specific, enhanced and custom ICs, plus die sales options

### Commitment

- » Experience in supplying components for a wide range of medical applications
- » Global support infrastructure
- » Local technical support and distribution
- » Systems and applications insight
- » Tools and training

### Quality and Reliability

- » Long product lifetimes and a robust product obsolescence policy to ensure continuity of supply
- » Ability to serve customers of all sizes with a variety of needs
- » Enhanced qualification and screening available with enhanced package offering
- » Member of industry-standard organizations and alliances, such as the Continua Health Alliance
- » ISO 9001 certified with worldwide manufacturing and R&D capabilities
- » Robust process change control notification (PCN) and industry leading product traceability

Learn more at [www.ti.com/medical-avnet](http://www.ti.com/medical-avnet).

## DOWNLOAD TIS MEDICAL APPLICATION GUIDES

- » Medical Applications Guide (full version)
- » Consumer Medical Applications Guide
- » Diagnostic, Patient Monitoring and Therapy Applications Guide
- » Medical Imaging Applications Guide
- » Medical Instruments Applications Guide

[www.ti.com/medicalguides-avnet](http://www.ti.com/medicalguides-avnet)

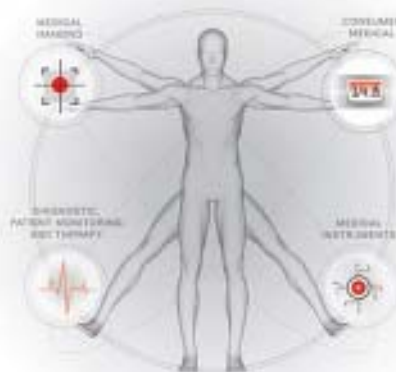

## TI ICs FOR MEDICAL APPLICATIONS

### CONSUMER MEDICAL

- » Blood pressure monitors
- » Heart rate monitors
- » Blood analyzers
- » Digital thermometers
- » Pulse oximetry
- » Telehealth aggregation manager, with or without video output

### MEDICAL IMAGING

- » Ultrasound
- » Computed tomography (CT)
- » Magnetic resonance imaging (MRI)
- » Digital X-ray
- » PET scanners

### DIAGNOSTIC, PATIENT MONITORING AND THERAPY

- » Electrocardiograms (ECGs)
- » Electroencephalograms (EEGs)
- » Blood oxygen (pulse oximetry)
- » Ventilation/respiration
- » Defibrillators
- » Dialysis machines

### MEDICAL INSTRUMENTS

- » Lab equipment
- » Analytical instruments
- » Surgical instruments
- » Dental instruments
- » Endoscopes and smart pills
- » Robotics prosthetics
- » Hospital beds

# The power of Avnet: now conveniently available online!



## PRODUCTS

- Over 3.8 Million Parts Online
- Over 1.9 Million Parts in Quantities of 1

## SEARCH/SORT/COMPARE

- Top Sellers
- Alternate Parts
- Prototype Quantities

## DESIGN

- Parametric Search
- Technical Support
- Development Tools & Kits

## ORDER AND DELIVERY

- No Minimum Orders
- No Handling Charges
- Global Shipping

Order your parts today. Online or by phone. Fast.  
[www.AvnetExpress.com](http://www.AvnetExpress.com) 1.866.AVNET4U  
 View the online demo today at [www.AvnetExpress.com/Demo](http://www.AvnetExpress.com/Demo)



*Accelerating Your Success™*

©Avnet, Inc. 2011. All rights reserved. AVNET is registered trademark of Avnet, Inc.

Avnet Electronics Marketing is one of the world's largest technology, marketing, distribution and services companies, offering leading Design Chain services combined with world-class Supply Chain services in support of the electronics industry.

